

# Electric Brake

## 10K and 12K Axles

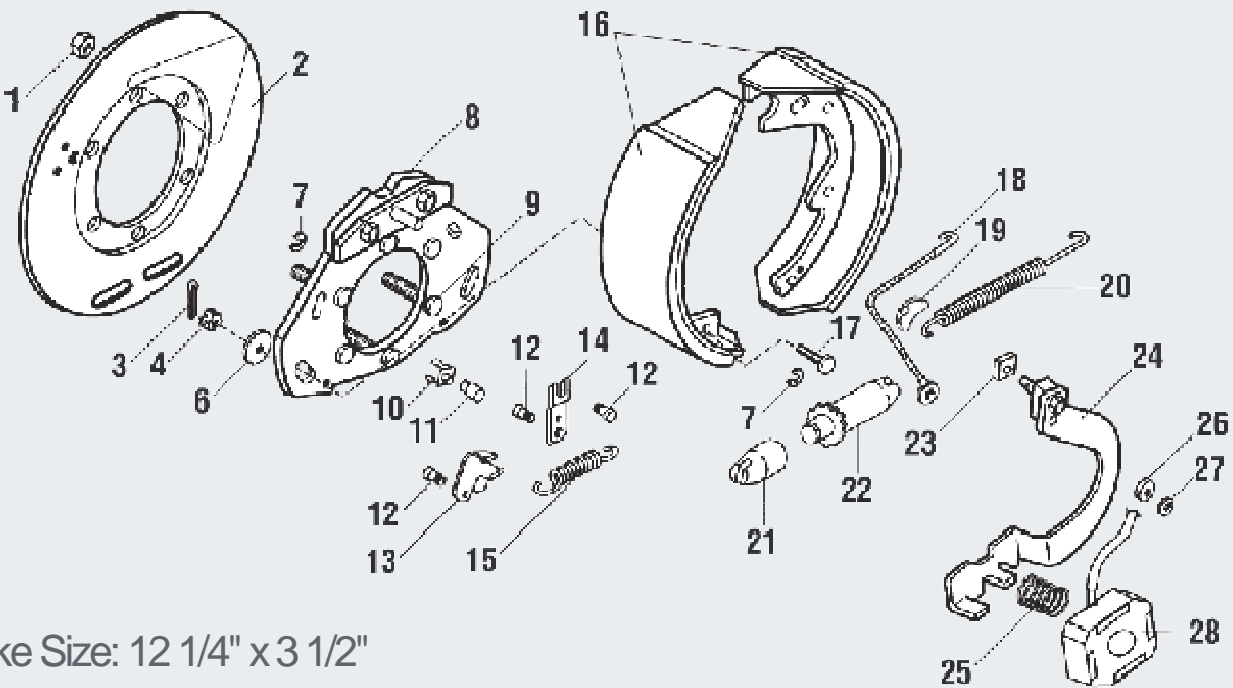

Brake Size: 12 1/4" x 3 1/2"

### Parts List

No.	Brake Part Description	AL-KO Part No.	Hayes Part No.	No.	Brake Part Description	AL-KO Part No.	Hayes Part No.
0	RH Brake Assembly Complete (shown)	568255.1	568255.1	14	Self Adjuster Bias Lever	568241	096323
0	LH Brake Assembly Complete	568255.2	568255.2	15	Self Adjuster Spring	568239	096523
1	Brake Attaching Nut, 1/2" - 20	568022	090617	16	Shoe & Lining Kit	K568251	K568251
2	Dust Cover Assembly RH (AL-KO only)	568229.1	—	17	Shoe Hold Down Bolt	568227	090759
2	Dust Cover Assembly LH (AL-KO only)	568229.2	—	18	Cable Assembly	568245	096936
2A	Upper RH Dust Cover (Hayes only)	—	09693402	19	Cable Guide	568246	5758
2B	Upper LH Dust Cover (Hayes only)	—	09693403	20	Shoe Retract Spring	568226	5609
2C	Lower 1/2 Dust Cover (Hayes only)	—	09693401	21	Self Adjuster Socket	568272	602723
3	Shoe Hold Down Cotter Pin	568224	091905	22	RH Adjuster Assembly (shown)	568256	602717
4	Shoe Hold Down Nut	568233	090647	22	LH Adjuster Assembly	568257	602718
6	Shoe Hold Down Washer	568232	090541	23	Slipper Block	568242	096939
7	Pin Retaining "C" Clip	568249	096806	24	RH Lever Assembly (shown)	568236	60313501
8	Backing Plate Assembly	—	—	24	LH Lever Assembly	568237	60313601
9	Brake Mounting Stud 1/2" - 20	568250	090755	25	Magnet Spring	568240	09652915
10	Strain Relief Adapter	568258	096937	26	Lever Retaining Washer	568248	090540
11	Strain Relief	568243	092715	27	Lever Retaining "E" Clip	568247	096803
12	Self Adjuster Pivot Pin	568238	096618	28	Magnet	—	—
13	RH Auto Adjust Lever (shown)	568253	096321	29	Magnet Assembly Kit	K568252	K568252
13	LH Auto Adjust Lever	568254	096322		contains #10, #11, #25, #28		

**WARNING:** AL-KO Kober Corporation manufacture hubs and drums that are compatible with many wheels used in the trailer industry that have matching bolt patterns. AL-KO does not manufacture wheels, nor do they recommend a specific wheel for compatibility with the hubs and drums they manufacture. The wheel manufacturer should be contacted for proof of compatibility before use.